

Size of screw-neck vial (cc)	d1 (mm)	d2 (mm)	d4 (mm)	h1 (mm)	h2 (mm)	S1 (mm) ±0.05
5	18 ±0.2	14.0 -0.4	8.6 ±0.2	45 ±0.5	29	1.2
7.5	22 ±0.2	18.0 -0.5	11.5 ±0.2	40 ±0.5	23	1.2
10	24 ±0.2	18.0 -0.5	11.5 ±0.2	45 ±0.5	28	1.2
15	24 ±0.2	18.0 -0.5	11.5 ±0.2	60 ±0.5	43	1.2
20	30 ±0.3	22.0 -0.5	15.2 ±0.25	55 ±0.7	36	1.2
25	30 ±0.3	22.0 -0.5	15.2 ±0.25	65 ±0.7	46	1.2
30	30 ±0.3	22.0 -0.5	15.2 ±0.25	75 ±0.7	56	1.2

d1 : Body diameter
d2 : Outer diameter
d4 : Inner diameter

h1 : Total height
h2 : Cylinder height

s1 : Body wall thickness

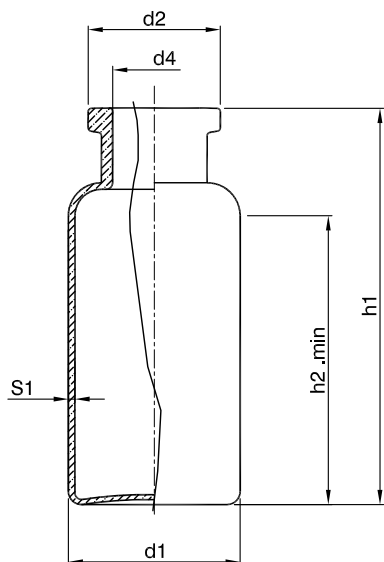

Size of injection vial (ml)	Overflow capacity (ml)	d1 (mm)	d2 (mm) +0.2 - 0.3	d4 (mm) ±0.2	h1 (mm)	h2 (mm)	S1 (mm)
2 R	4 ±0.5	16 ±0.15	13.0	7.0	35 ±0.5	22	1.0 ±0.04
4 R	6 ±0.5	16 ±0.15	13.0	7.0	45 ±0.5	32	1.0 ±0.04
6 R	10 ±0.5	22 ±0.2	20.0	12.6	40 ±0.5	26	1.0 ±0.04
8 R	11.5 ±0.5	22 ±0.2	20.0	12.6	45 ±0.5	31	1.0 ±0.04
10 R	13.5 ±1.0	24 ±0.2	20.0	12.6	45 ±0.5	30	1.0 ±0.04
15 R	19 ±1.0	24 ±0.2	20.0	12.6	60 ±0.5	45	1.0 ±0.04
20 R	26 ±1.5	30 ±0.25	20.0	12.6	55 ±0.7	35	1.2 ±0.05
25 R	32.5 ±1.5	30 ±0.25	20.0	12.6	65 ±0.7	45	1.2 ±0.05
30 R	37.5 ±1.5	30 ±0.25	20.0	12.6	75 ±0.7	55	1.2 ±0.05

d1 : Body diameter
d2 : Outer diameter
d4 : Inner diameter

h1 : Total height
h2 : Cylinder height

s1 : Body wall thickness